



HEIDENHAIN



Preliminary
Product Information

ACANTO **AT 1200** **AT 3000**

Absolute Length Gauges

October 2009

ACANTO

Absolute Length Gauges with EnDat Interface

- **Very compact dimensions**
- **Protected from splash water**

Thanks to their small dimensions, the ACANTO length gauges are the product of choice for multipoint inspection apparatus and testing equipment. Absolute position measurement provides the measured values immediately after switch-on. This is particularly favorable on measuring stations with numerous measuring points: as the measured value is already generated in the length gauge there is no need for the counting electronics for each measuring point that would otherwise be necessary.

Plunger actuation

The **AT 1218** and **AT 3018** length gauges feature a spring-tensioned plunger that is extended at rest. In the pneumatic length gauges **AT 1217** and **AT 3017** the plunger is retracted to its rest position by the integral spring. It is extended to the measuring position by application of compressed air.

Mounting

The ACANTO length gauges are fastened by their 8h6 standard clamping shank.

Interface

The ACANTO length gauges have a bidirectional serial EnDat interface for transmission of the absolute position values and internal encoder information.

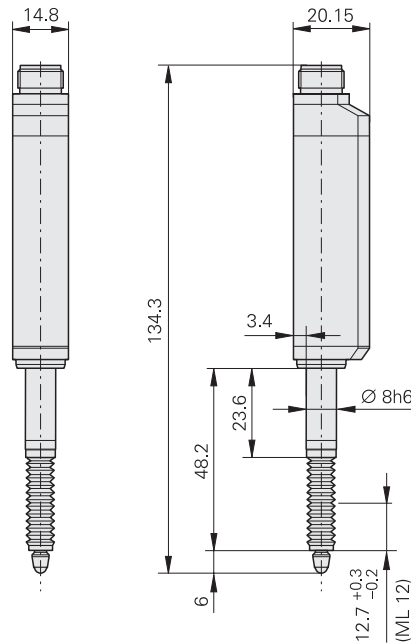

AT 1218

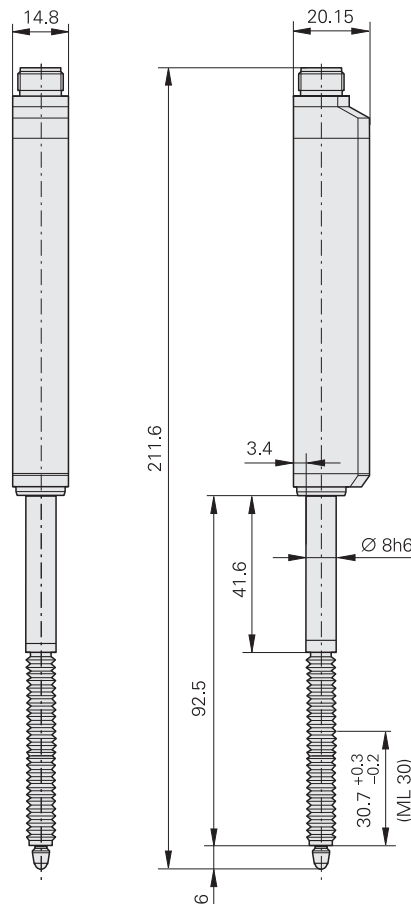

AT 3018

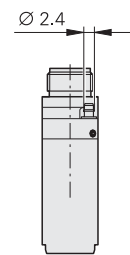

AT 1217/3017

Dimensions in mm

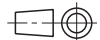

Tolerancing ISO 8015

ISO 2768 - m H

< 6 mm: ±0.2 mm

⊙ = Beginning of measuring length

Mechanical Data

Plunger actuation

Position of plunger at rest

Measuring standard

System accuracy

Measuring range

Gauging force²⁾ with retracting plunger
Vertically downward
Vertically upward
Horizontal

Mech. permissible traversing speed

Radial force

Operating attitude

Vibration 55 to 2000 Hz

Shock 11 ms

Protection EN 60529

Operating temperature

Fastening

Weight²⁾ without cable

Electrical Data

Absolute position values

Ordering designation

Resolution

Processing time

Electrical Connection

Cable length

Power supply

AT 1218	AT 3018 ¹⁾	AT 1217	AT 3017 ¹⁾
By measured object Extended		Pneumatic Retracted	
DIADUR graduation on glass			
± 2 µm			
12 mm	30 mm	12 mm	30 mm
0.6 to 1.8 N 0.4 to 1.6 N 0.5 to 1.7 N	0.7 to 2.3 N 0.3 to 1.9 N 0.5 to 2.1 N	0.0 to 2.5 N (depending on pressure and operating attitude)	0.0 to 3.0 N (depending on pressure and operating attitude)
≤ 60 m/min			
≤ 0.5 N (mechanically permissible)			
Any			
≤ 100 m/s ² (EN 60068-2-6) ≤ 500 m/s ² (EN 60068-2-27)			
IP 64			
10 to 40 °C; ref. temperature 20 °C			
Clamping shank Ø 8h6			
80 g	100 g	80 g	100 g

AT 1200



EnDat
EnDat 2.2
EnDat 22
23 nm
≤ 5 µs
M12 flange socket, axial
≤ 100 m with HEIDENHAIN cable
3.6 ... 14 V / < 150 mA at 5 V

AT 3000







1) Scheduled availability: Mid of 2010
2) Preliminary specifications

Electrical Connection





Cable with M12 connecting element, 8-pin

EnDat 22 without
incremental signals

PUR connecting cables		8-pin: [(4 × 0.14 mm ²) + (4 × 0.34 mm ²)] Ø 6 mm
Complete with connector (female) and coupling (male)		368330-xx
Complete with connector (female) and D-sub connector (female) for IK 220		533627-xx
Complete with connector (female) and D-sub connector (male) for IK 215 and ND 28x/1000/2000 position display units		524599-xx
With one connector (female)		634265-xx ¹⁾

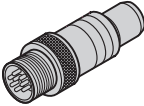
¹⁾ Connecting element must be suitable for 8 MHz signal transmission.

Pin layout

8-pin coupling M12									
			Power supply				Absolute position values		
	8	2	5	1	3	4	7	6	
	U_P	Sensor U _P	0V	Sensor 0V	DATA	DATA	CLOCK	CLOCK	
	Brown/Green	Blue	White/Green	White	Gray	Pink	Violet	Yellow	

Shield on housing; **U_P** = Power supply voltage

Vacant pins or wires must not be used!

The sensor line is connected inside the encoder to the supply line.

HEIDENHAIN

DR. JOHANNES HEIDENHAIN GmbH

Dr.-Johannes-Heidenhain-Straße 5

83301 Traunreut, Germany

☎ +49 8669 31-0

FAX +49 8669 5061

E-mail: info@heidenhain.de

www.heidenhain.de

For more information

- Catalog: *Length Gauges*