



Technical Information

Linear Encoders with Single-Field Scanning

HEIDENHAIN linear encoders are used as position measuring systems on machine tools, in handling and automation technology, and in measuring and inspecting equipment. Sealed linear encoders are protected from dust, chips and splash fluids and are ideal for operation on machines and systems with harsh operating environments in regard to contamination. Because of their compact design, they are also very effective in direct drives and assembly automation. Exposed linear encoders are used on fast, precise machines and systems, such as production and measuring equipment in the semiconductor industry, ultra-precision machines, measuring machines and precision devices in linear metrology, direct drives, etc.

The most important requirements of these applications are:

- High positioning accuracy
- High traversing speed
- High machine availability
- Finely tuned velocity control

With the single-field scanning principle for linear encoders, HEIDENHAIN is fulfilling these requirements. This method is characterized particularly by significantly reduced sensitivity to contamination, and higher quality of the output signal.

Photoelectric scanning

Like most HEIDENHAIN encoders, the linear encoders operate according to the principle of photoelectrically scanning a regularly structured measuring standard. In the imaging scanning principle, as it is used for example in the LS sealed linear encoders, a structured scale moves relative to an opposed grating—the index grating—with an identical or similar structure. The incident light is modulated: if the gaps are aligned, light passes through. If the lines of one grating coincide with the gaps of the other, no light passes through. Photovoltaic cells convert these variations in light intensity into electrical signals.

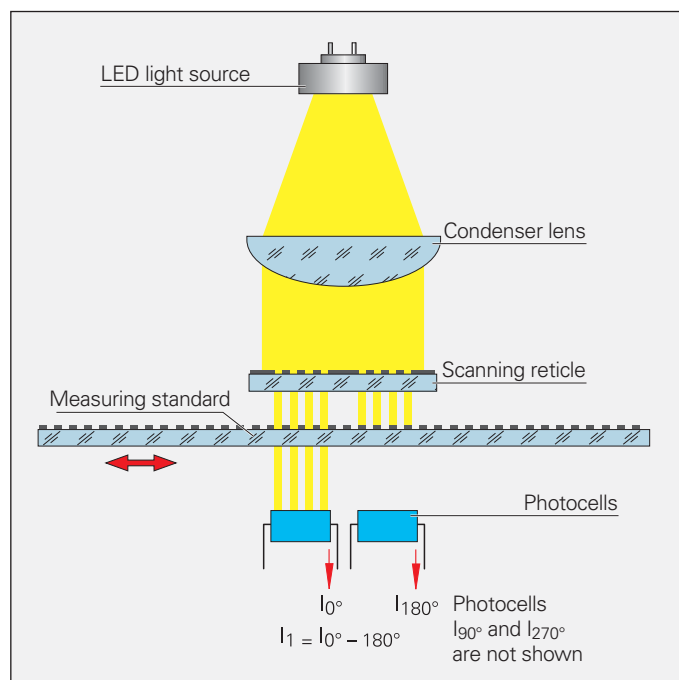

Signal Generation with the Imaging Scanning Principle

The type of scanning is crucial for the quality of the output signals and therefore both for the positioning accuracy and for traversing speed.

Optical systems are sensitive by nature to contamination of all types. With the new single-field scanning principle, it has become possible to improve both qualities decisively. This illustration compares it with the previous 4-field scanning.

Signal generation with 4-field scanning

The scanning reticle has scanning fields whose gratings are offset to one another by one fourth of a grating period each. The corresponding photovoltaic cells generate sinusoidal signals, phase-shifted to one another by 90° (elec.). These scanning signals are not at first symmetrical about the zero line. For this reason the photovoltaic cells are connected in a push-pull circuit, producing two output signals I_1 and I_2 in symmetry with respect to the zero line and electrically phase-shifted by 90° .

Signal generation with single-field scanning

The scanning reticle has one large-area grating whose grating period differs slightly from that of the scale. This generates an optical beat along the length of the scanning field: at some positions the lines coincide and let the light through. At other locations the lines and gaps coincide, causing a shadow. In between, the gaps are only partially covered. This causes a type of optical filtering that allows homogeneous signals of a shape very close to a sine wave. Instead of individual photovoltaic cells, one large-area, specially structured photosensor generates the four 90° electrically phase-shifted scanning signals.

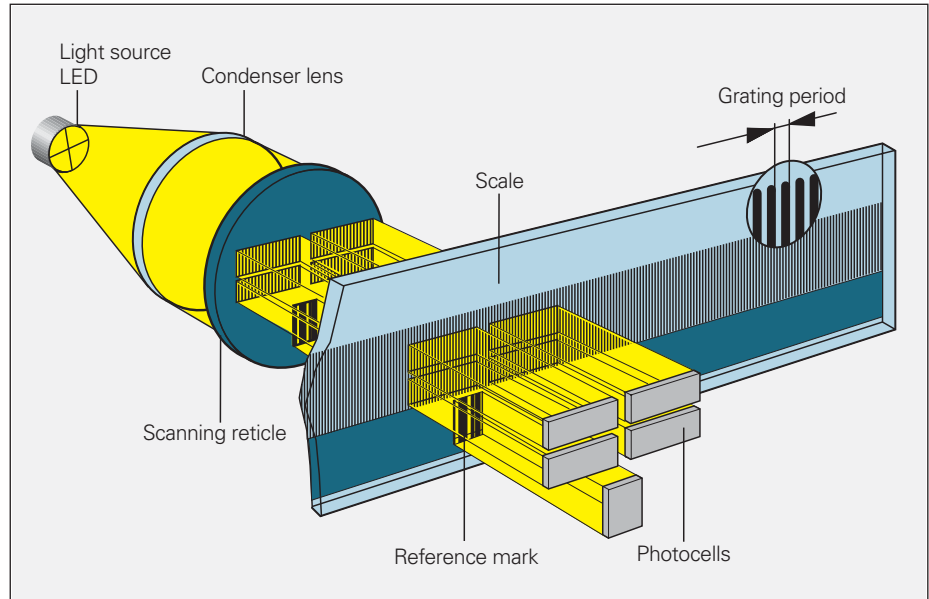

Photoelectric scanning in accordance with the imaging principle and 4-field scanning

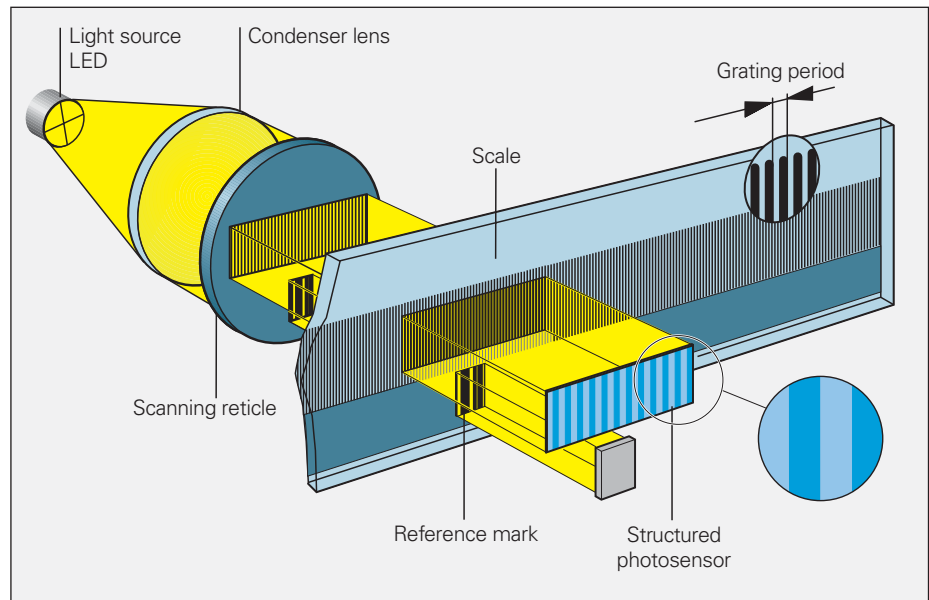

Photoelectric scanning in accordance with the imaging principle and single-field scanning

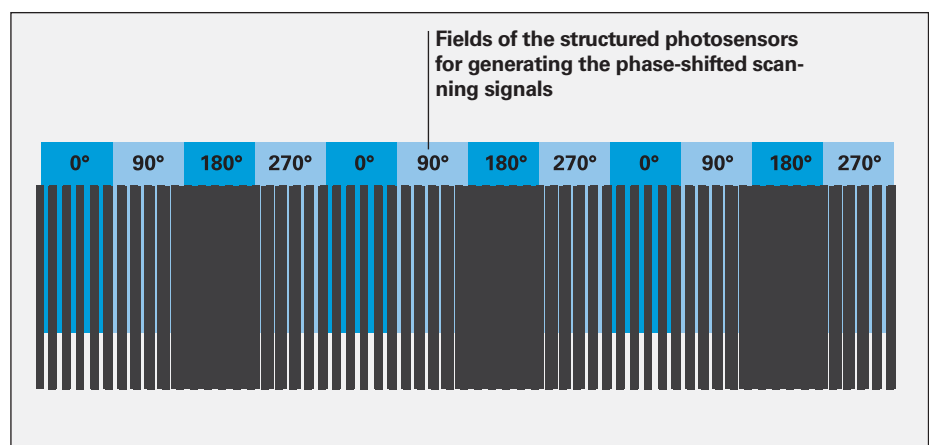

Imaging the light/dark fields of the scanning reticle and scale on the structured photosensor

Benefits of Single-Field Scanning

Insensitive to contamination

The large scanning area over the entire width of the scale grating and the arrangement of several scanning fields in succession make the encoders with single-field scanning extremely insensitive to contamination. The results of corresponding contamination tests prove this: even when contamination over large areas is simulated, the encoder continues to provide high-quality signals. The position error remains far below the value specified for the accuracy grade of the encoder.

In many cases, depending on the contamination, this can even prevent encoder failure where 4-field scanning cannot.

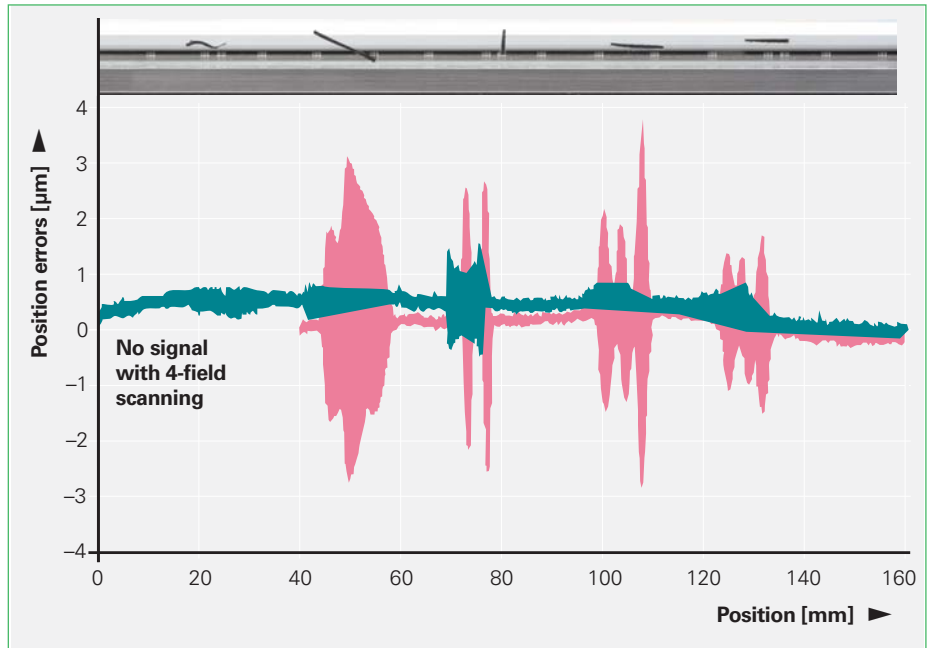

Effects of contamination with 4-field scanning (red) and single-field scanning (green)

This example shows the influence of contamination on the output signals.

In the XY representation on an oscilloscope the signals form a Lissajous figure. Ideal output signals appear as a concentric inner circle. Deviations in the circular form and position are caused by position error within one signal period (see Measuring Accuracy) and therefore go directly into the result of measurement. The size of the circle, which corresponds with the amplitude of the output signal, can vary within certain limits without influencing the measuring accuracy.

In the encoder with single-field scanning, however, one sees only a small change in the amplitudes. In the XY display, only the diameter changes slightly—a sure sign of very low position error. This type of contamination has very striking effects with 4-field scanning: Because two scanning fields are involved, the XY display shows an extremely eccentric ellipse. This causes a total failure of the encoder at this position.

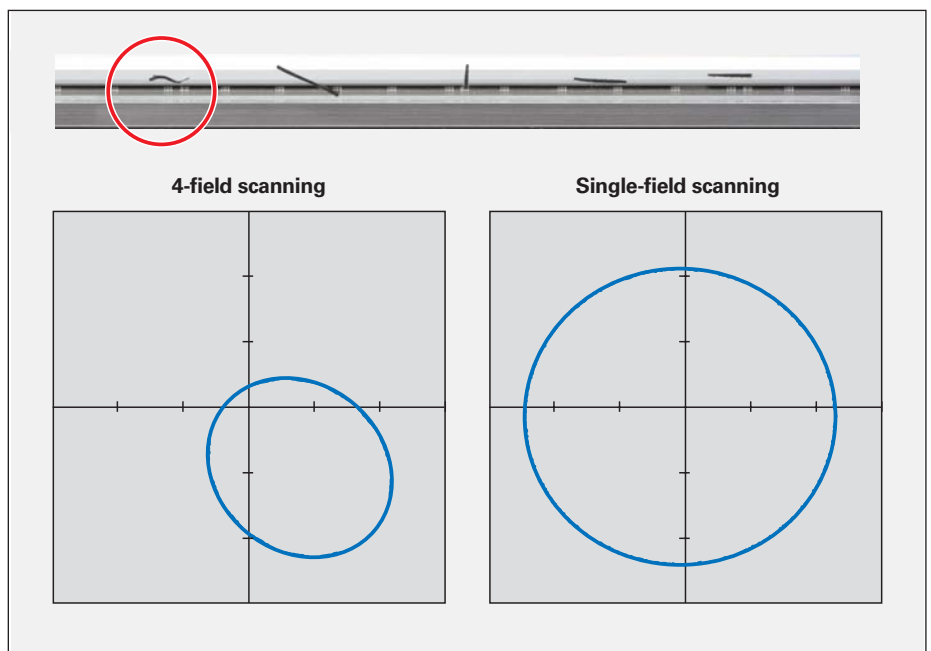

Effects of contamination on the output signals

Better signal quality

Encoders from HEIDENHAIN acquire their accuracy first of all from the high quality of the line grating on the measuring standard. The sinusoidal output signals are interpolated in order to achieve application-oriented measuring steps of 0.1 μm and finer. This results in additional position errors within one signal period because of asymmetric signals and deviations from the sinusoidal form. These position errors are random and can therefore not be compensated.

The single-field scanning method has considerable influence here: The large scanning field and the special optical filtering generate scanning signals with high constancy and good sinusoidal form over the entire path of traverse. This substantially reduces position error within the signal period.

This is very visible on the XY display of the oscilloscope: The output signals of the linear encoders with single-field scanning show a more circular form and less signal noise.

This is the prerequisite for

- Small position error within one signal period
- Good control quality for direct drives, which means improved, finely tuned velocity control
- High repeatability

Even high, electrically permissible traversing speeds are made possible by the high-quality output signals of single-field scanning. Because the signal amplitudes are only slightly influenced by velocity, stable output signals ensure reliable interpolation even at increased traversing speeds.

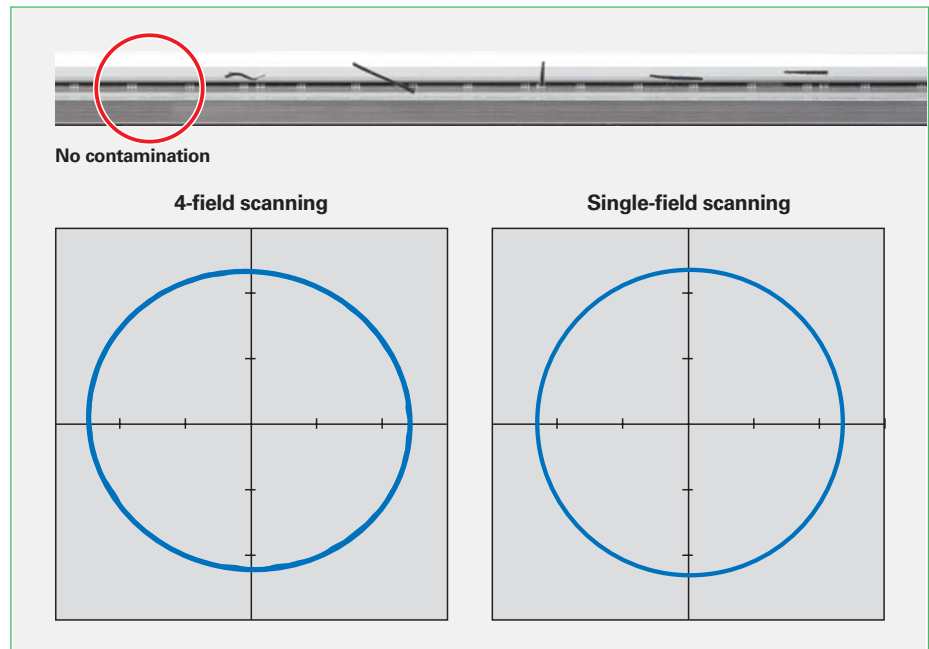

Signal quality with 4-field and single-field scanning

HEIDENHAIN

DR. JOHANNES HEIDENHAIN GmbH

Dr.-Johannes-Heidenhain-Straße 5

83301 Traunreut, Germany

☎ +49 (8669) 31-0

FAX +49 (8669) 50 61

E-Mail: info@heidenhain.de

www.heidenhain.de

For more information:

- Brochure: *Exposed Linear Encoders*
- Brochure: *Linear Encoders for Numerically Controlled Machine Tools*

