



HEIDENHAIN



Product Information

LS 1679

Incremental Linear Encoder
with Integrated Roller Guide

February 2007

LS 1679

- Incremental linear encoder for measuring steps to 5 µm or 1 µm
- Integrated wear-free roller guide with steel ball bearings on steel rod
- Large mounting tolerances for connecting by coupling rod
- Reference marks selectable every 50 mm

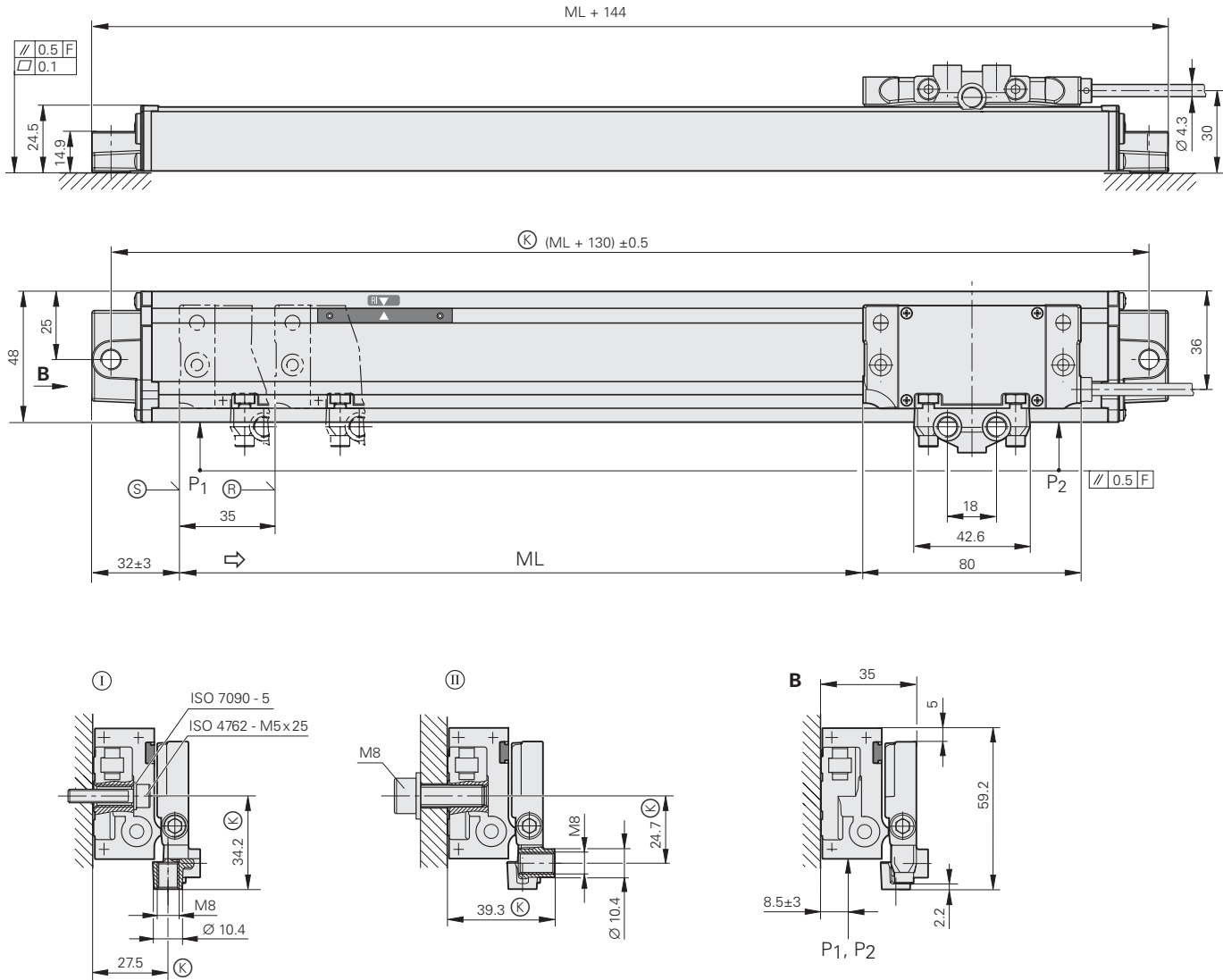

Dimensions in mm



Tolerancing ISO 8015
 ISO 2768 - m H
 < 6 mm: ±0.2 mm

- ⓪, ① = Mounting options
- F = Machine guideway
- P = Gauging points for alignment
- Ⓚ = Required mating dimensions
- Ⓢ = Beginning of measuring length (ML)
- Ⓡ = Reference mark position
- ⇨ = Direction of scanning unit motion for output signals in accordance with interface description



Specifications	LS 1679	
Measuring standard Expansion coefficient	Glass scale with DIADUR graduation α_{therm} approx. $(8 \pm 1) \times 10^{-6} \text{ K}^{-1}$	
Accuracy grade	$\pm 10 \mu\text{m}$	
Measuring length ML* in mm	70, 120, 170, 220, 270, 320, 370, 420, 470 ¹⁾	
Reference marks*	One, located 35 mm from the beginning or end of the measuring length, or selectable via magnet every 50 mm	
Incremental signals	□□TTL	
Grating period	100 μm	
Integrated interpolation* Signal period	5-fold 20 μm	25-fold 4 μm
Edge separation a	$\geq 1.6 \mu\text{s}$	$\geq 0.8 \mu\text{s}$
Power supply without load	5 V \pm 5 % / < 120 mA	
Electrical connection	Connecting cable, cable outlet at mounting block, left or right	
Length*	3 m / 6 m ¹⁾	
Connection*	With connector, male, 12-pin; coupling, male, 12-pin or with D-sub connector, 9-pin	
Traversing speed	$\leq 60 \text{ m/min}$	
Required moving force	$\leq 5 \text{ N}$	
Vibration 55 to 2000 Hz Shock 11 ms Acceleration	$\leq 150 \text{ m/s}^2$ (IEC 60068-2-6) $\leq 300 \text{ m/s}^2$ (IEC 60068-2-27) $\leq 30 \text{ m/s}^2$ in measuring direction	
Operating temperature	0 to 50 °C	
Protection IEC 60529	IP 53 when mounted according to the mounting instructions	
Weight	0.46 kg + 1.34 kg/m measuring length	

* Please select when ordering

¹⁾ Further lengths available on request

Montage

1. Aligning the scale

Dead stop

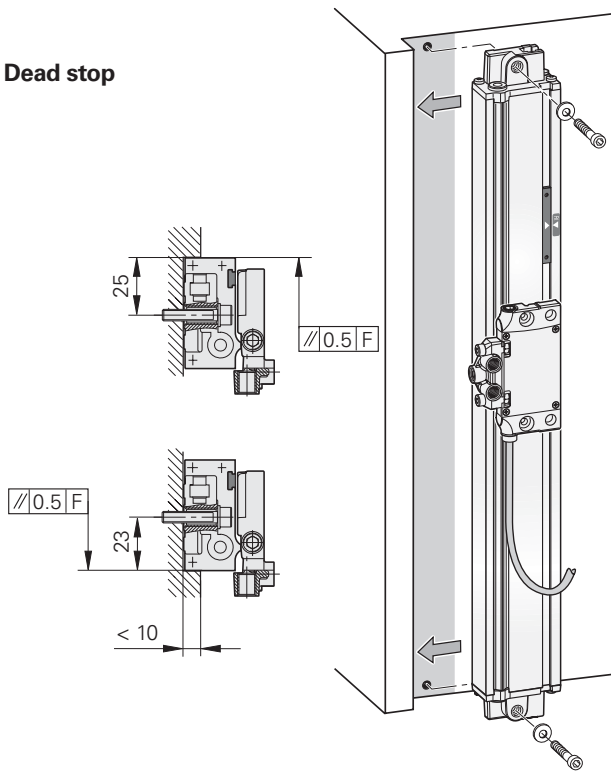

Stop pins

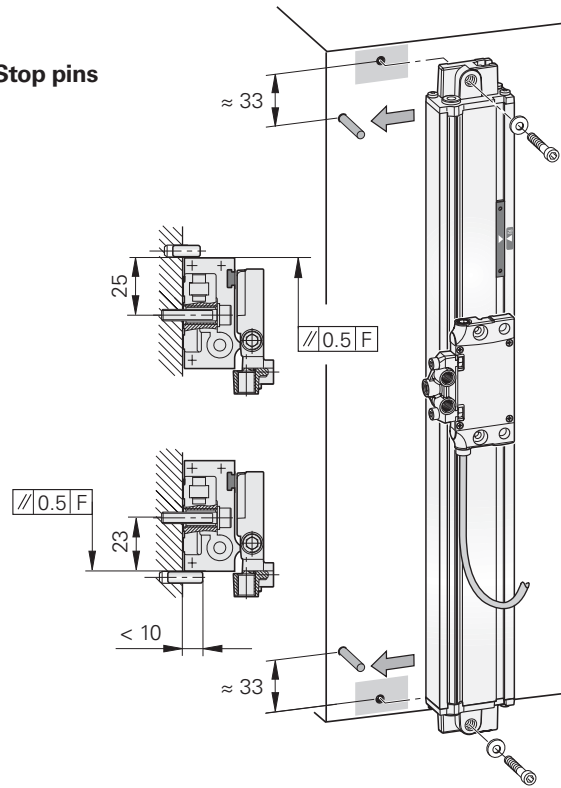

2. Connecting the scanning unit by coupling rod

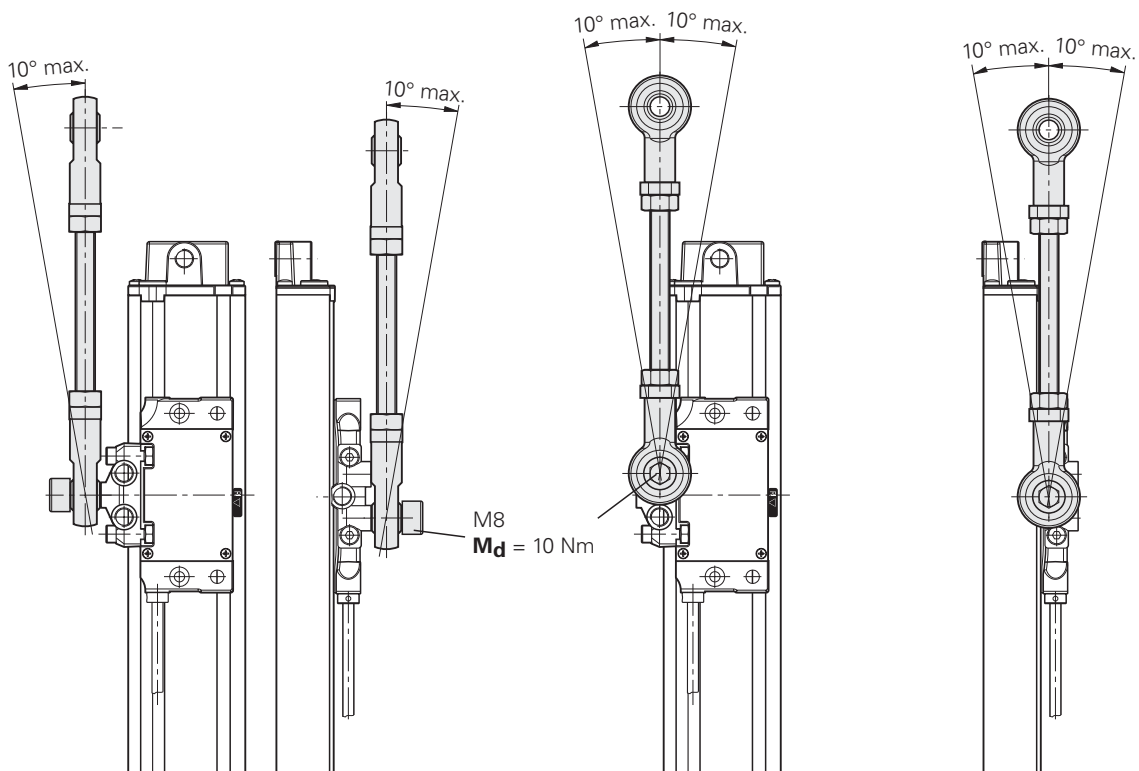

F = Machine guideway

Mounting Accessories

Coupling rod

For coupling the LS 1679 to press brakes and bending machines, includes bolts

ID 538768-01

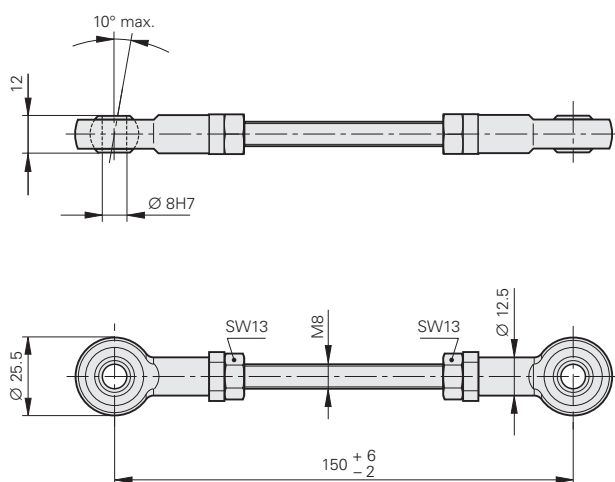







Dimensions in mm



Tolerancing ISO 8015
ISO 2768 - m H
< 6 mm: ± 0.2 mm

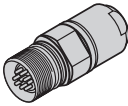
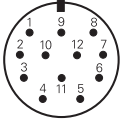

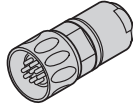
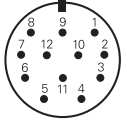
Electrical Connection

Pin Layout

12-pin M23 flange socket or M23 coupling					12-pin M23 connector								
													
	Power supply				Incremental signals						Other signals		
	12	2	10	11	5	6	8	1	3	4	7	/	9
	U_P	Sensor U_P	0V	Sensor 0V	U_{a1}	\overline{U}_{a1}	U_{a2}	\overline{U}_{a2}	U_{a0}	\overline{U}_{a0}	$\overline{U}_{aS}^{1)}$	Vacant	Vacant ²⁾
	Brown/ Green	Blue	White/ Green	White	Brown	Green	Gray	Pink	Red	Black	Violet	–	Yellow

Shield on housing; U_P = power supply voltage

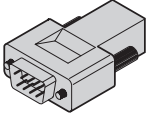
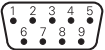





Sensor: The sensor line is connected internally with the corresponding power line



9-pin D-sub connector for DELEM control								
								
	Power supply		Incremental signals					
	9	5	3	8	2	7	1	6
HEIDENHAIN	U_P	0V	U_{a1}	\overline{U}_{a1}	U_{a2}	\overline{U}_{a2}	U_{a0}	\overline{U}_{a0}
DELEM			T_1	\overline{T}_1	T_2	\overline{T}_2	T_0	\overline{T}_0
	Brown/Green + blue	White/Green + white	Brown	Green	Gray	Pink	Red	Black

Shield on housing; U_P = power supply voltage

Sensor: The sensor line is connected internally with the corresponding power line

Connecting Elements and Cables

PUR connecting cable Ø 8 mm For encoders with coupling or flange socket		PUR connecting cable Ø 8 mm For encoders with connector	
Complete with M23 connector (female) and M23 connector (male) 	12-pin 298399-xx	Complete with M23 coupling (female) and M23 connector (male) 	12-pin 298400-xx
Complete with M23 connector (female) and M23 connector (male) 	12-pin 298399-xx	Complete with M23 coupling (female) and M23 connector (male) 	12-pin 298400-xx
With one M23 connector (female) 	12-pin 309777-xx	With one M23 coupling (female) 	12-pin 298402-xx
Cable only 	12-pin 244957-01	[4(2 x 0.14 mm ²) + (4 x 0.5 mm ²)]	

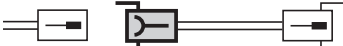
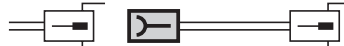
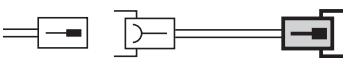
M23 connectors and couplings			
Coupling on encoder cable 	M23 coupling (male)	Connector on encoder cable 	M23 connector (male)
For cable diameter 6 mm	12-pin 291698-03	For cable diameter 6 mm	12-pin 291697-07
Mating element for coupling to encoder cable or flange socket 	M23 connector (female)	Mating element on connecting cable for encoder connector 	M23 coupling (female)
For connecting cable diameter 8 mm	12-pin 291697-05	For connecting cable diameter 8 mm	12-pin 291698-02
Connector for connection to subsequent electronics 	M23 connector (male)		
For connecting cable diameter 8 mm	12-pin 291697-08		

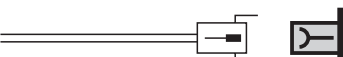
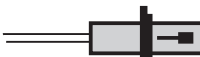
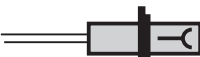
Couplings and M23 flange socket for mounting			
	M23 flange socket (female)		M23 coupling on mounting base with flange (male)
	12-pin 315892-08	For cable diameter 8 mm	12-pin 291698-31
			M23 coupling on mounting base with flange (female)
		For cable diameter 8 mm	12-pin 291698-07

HEIDENHAIN

DR. JOHANNES HEIDENHAIN GmbH

Dr.-Johannes-Heidenhain-Straße 5

83301 Traunreut, Germany

 +49 (86 69) 31-0

 +49 (86 69) 50 61

E-Mail: info@heidenhain.de

www.heidenhain.de

For more information

- *Sealed Linear Encoders* brochure